

Data sheet

Electronic Oil Burner Control OBC 82A.12

Description



The microprocessor based control OBC 82A.12 offers stable and precise timings independent of variations in supply voltage and ambient temperature.

The control is undervoltage protected in accordance with EN 298:2012. In case of

undervoltage the control will prevent the burner from starting and simultaneously show a flash code. Besides this, up to five other fault types can be read out as flash codes when the control is in lockout.

The design complies with the requirements of the RoHS and WEEE directive.

Application and features

- For 2 stage burners up to 30 kg/h
- For burners with or without preheater
- Precise and reproducible timings
- Limitation at 3 restarts by flame failure within the same operating period
- Limitation of 10 min. on preheating time
- Remote reset and alarm output
- Ignition out on terminal 6 and 7
- Indication of reason for lockout
- Indication of preheating and operation

Function

The OBC 82A.12 controls the cut-in and cut-out of the oil burner's components and monitors that the combustion cycle is performed safely. When the boiler thermostat (TR) cuts in, heating of the oil in the oil preheater (OFV) will begin. Once the release temperature is reached and the oil preheater's thermostat (OTR) cuts in, the burner motor will start the pre-purge and power will simultaneously be applied to the ignition (TT1/TT2). Following the pre-ignition and pre-purge time, the oil will be released by valve V1 being opened and subsequently V2 will be opened. When the boiler thermostat opens after the heating period power will be cut off and all relays at the outputs will open and be ready for the next start-up cycle.

Operating information

OBC 82A.12 is equipped with a two-coloured LED which displays both the operating status and can indicate the causes of errors leading to lockout. In the event of operating lockout, the cause of error can be read out as a flash code by holding down the reset button for at least 5 seconds and then releasing it. Undervoltage will, however, be displayed automatically. Reset can be performed directly in alarm mode (constant red light) or in flash code mode by pressing the reset button for at least 0.5 seconds but no more than 3 seconds. In flash code mode it is possible to return to alarm mode by holding down the reset button again for at least 5 seconds.

Normal operation

When the boiler thermostat (TR) cuts in, the reset button flashes green. As soon as the preheater thermostat (OTR) cuts in, the reset button lights up constant green. When the boiler thermostat cuts out, the green light turns off.

Errors during operation (flash codes):

- If the mains voltage falls below 185 V before start-up, the control will be blocked from starting. If the mains voltage falls below 170 V during operation, the oil supply and burner will be stopped. In both cases, the reset button will automatically flash 8 times. When the mains voltages reaches 185 V, the control will restart as normal. Please note that the control cannot be reset if the mains voltage is below 170 V.
- If the mains voltage exceeds 264 V, the control will automatically enter alarm mode. The purpose of the overvoltage cut out is not simply to protect the electronics in the control, but also the other components in the burner.
- If light is registered in the final stage of the pre-purge time, the control will not release oil and will enter alarm mode.
- If no flame is established at the start, i.e. by the end of the safety time, the control will enter alarm mode.

- In the event of a flame failure during operation, the oil supply will be cut off after no more than 1 second and the control will restart the burner. If flame failure occurs more than three times in the same operating period (TR connected), the control will enter alarm mode.
- If the release temperature in the preheater is not reached within 10 minutes, the control will enter alarm mode.

The OBC 82A.12 processor also monitor the outputs at TT1/TT2, V1 and V2. If errors like electrical noise (EMC) are registered at the outputs, the control will enter alarm mode.









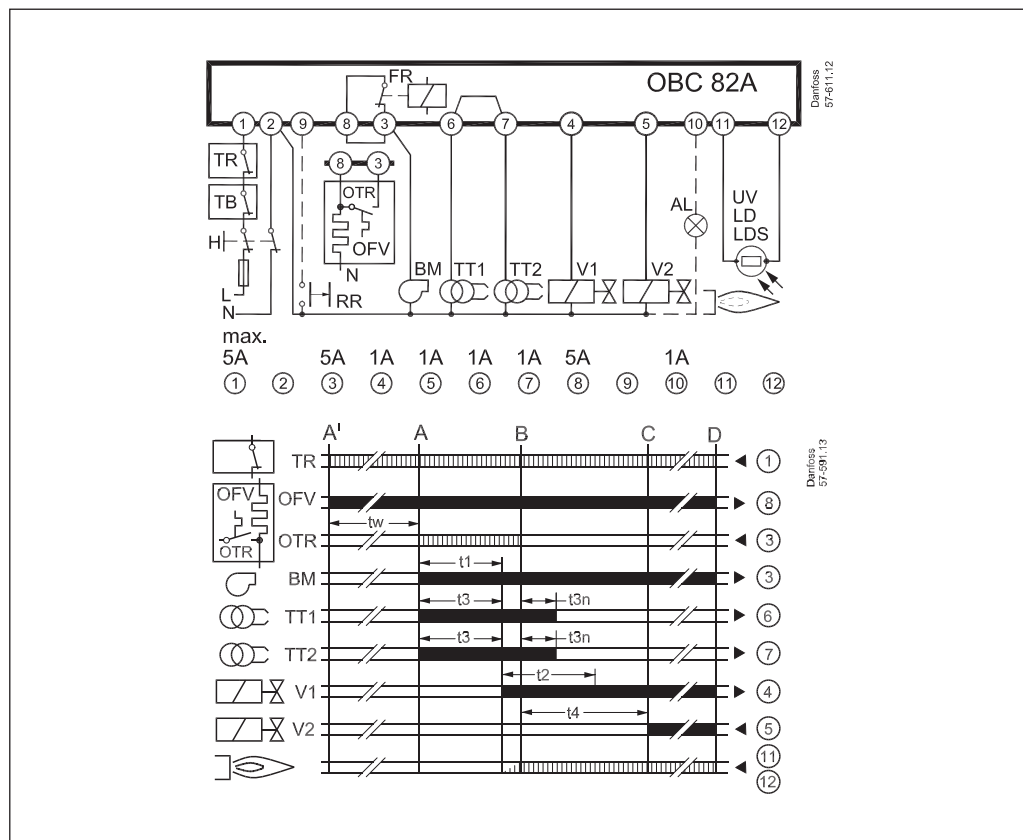

Flash codes



Event	Code
False light	2 flashes
No flame when safety time elapses	3 flashes
More than three restarts in the same cycle	4 flashes
Max. waiting time on preheater overrun (10 min)	5 flashes
Supply voltage above 264 V a.c.	6 flashes
Undervoltage <170 V (automatic)	8 flashes
Application failure (EMC)	constant flashes

Note:

OBC 81A.12 can only be reset while the supply voltage is connected.



Symbols	
 TR	Boiler thermostat
 TB	High temperature cutout
 TT	Ignition unit
 BM	Burner motor
 V	Solenoid valve
 (LD)	Photo unit or UV sensor
 AL	External alarm
L	Phase wire
N	Neutral wire
 OTR	Oil preheater / Oil preheater thermostat
 FR	Hold relay
 RR	Remote reset

Time function/explanation	
	Output signals of control
	Required input signals
A'	Initiation of burners with oil preheater OFV
A	Initiation of burners without oil preheater
B	Flame formation
C	Operation position
D	Burner stop
tw	Heating of oil preheater until OTR switches on
t1	Pre-purge 13 s
t2	Safety time 10 s
t3*	Pre-ignition 13 s
t4	Interval V1-V2 15 s
t3n	Post-ignition 5 s

* Due to the initialisation of the electronics, it may take up to two seconds before ignition is enabled.

** If the remote reset is activated more than 4 times within 15 minutes it is ignored and cannot be used before the 15 minutes has elapsed unless the power to the control box is turned off or if the reset is done on the control box itself.

Technical Data

Rated voltage	230 V~
Operating range	195-253 V~
Frequency	50-60 Hz \pm 6%
Consumption	6 VA
Reset	Immediately
Reaction time on flame failure	Max. 1 s
Undervoltage protection	< 170 V
Protection class	II
Pollution degree	2
Main fuse (terminal load, see electrical diagram)	Max. 10 A
Cable connection	Plate for 5 PG 11 screwed connections or plate with knockouts
Ambient temperature	-20 to +60°C
Installation	Any position
Enclosure	IP 40
Flame monitoring	UV, LD or LDS
Required flame signal	No flame / dark \leq 5 μ A
	Flame / light \geq 65 μ A
Max. cable length between OBC and UV, LD/LDS	20 m (installed separately)

Ordering

Description	Weight	Code no.
OBC 82A.12	200 g	057H8707
Base BHB	70 g	057H7010
Front plate for BHB, 5 \times PG 11	12 g	057H7011
Front plate for BHB, 8 \times knockouts	12 g	057H7012

Dimensions

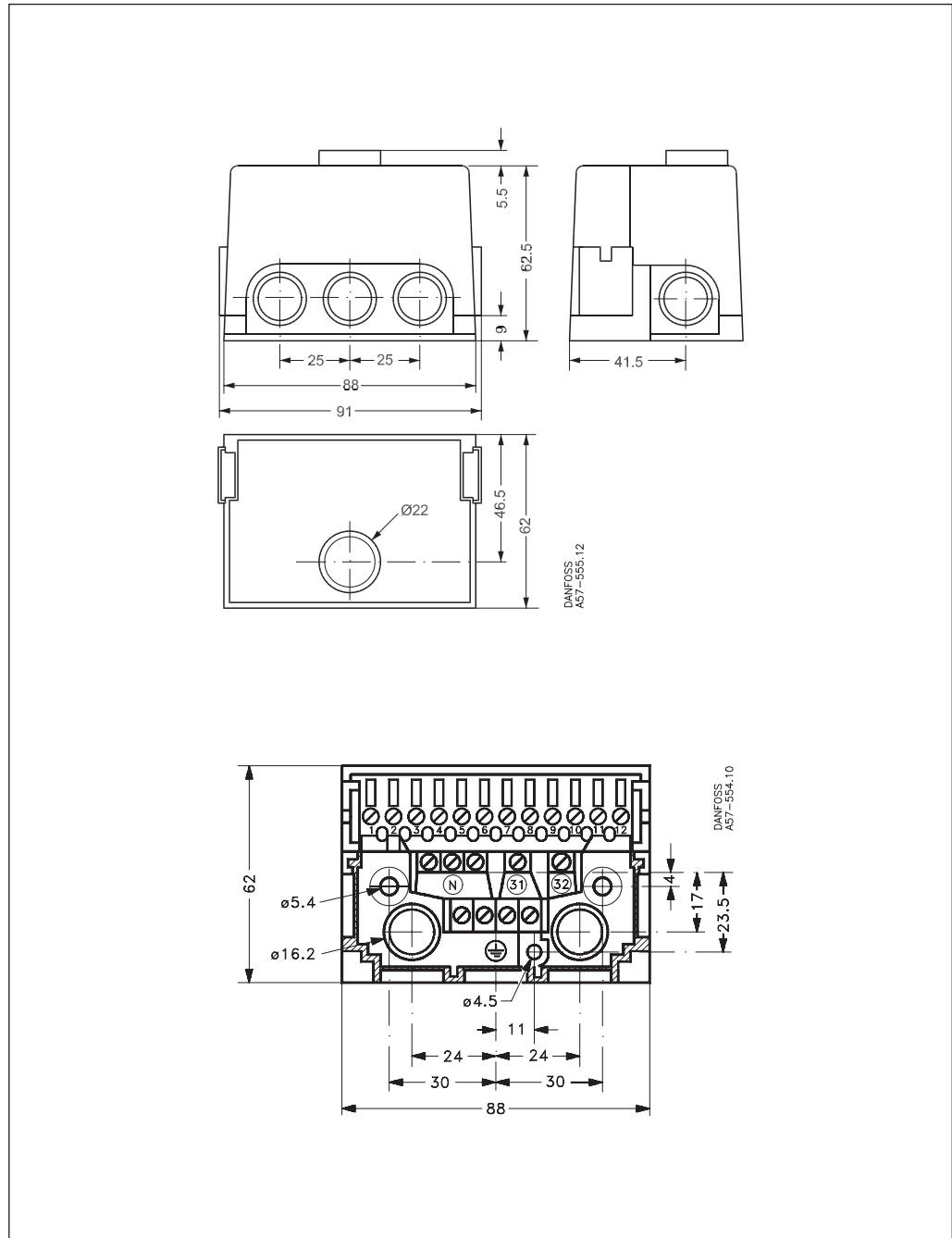

Additional documentation on burner components is available on <http://heating.danfoss.com/> or <https://store.danfoss.com/>

Danfoss A/S

Heating Segment • heating.danfoss.com • +45 7488 2222 • E-Mail: heating@danfoss.com

Danfoss can accept no responsibility for possible errors in catalogues, brochures and other printed material. Danfoss reserves the right to alter its products without no products already on order provided that such alterations can be made without subsequential changes being necessary in specifications already agreed. All trademarks in this material are property of the respective companies. Danfoss and all Danfoss logotypes are trademarks of Danfoss A/S. All rights reserved.