

BOILERSPARES LTD.

FB-04 Key Operated Boiler Blowdown Valve



E15 South City Business Park, Whitestown, Tallaght, Dublin 24
Tel : 01 4139864

FB-04 SSSG PN40 DN15/125 F4-F5

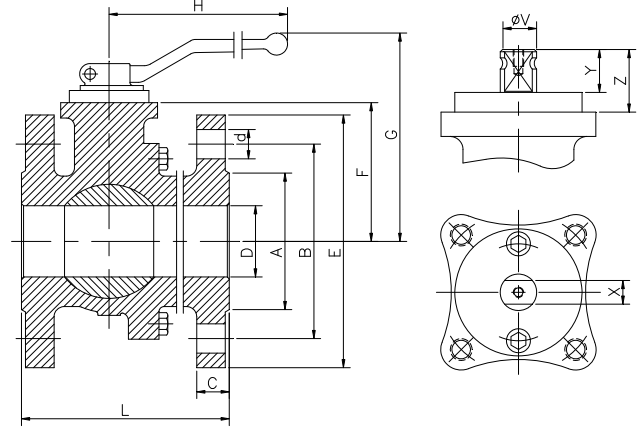
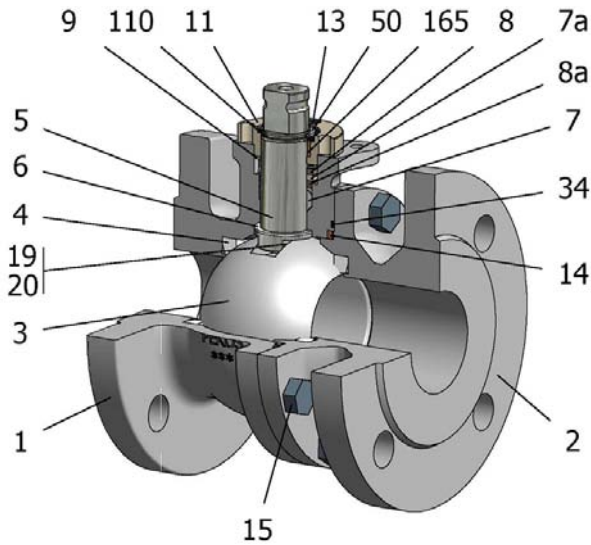

Position	Description	Material
01	Body 1	C.S. 1.0619
02	Body 2	C.S. 1.0619
03	Ball	S.S. 1.4408
04	Seat	PTFE+CG
05	Stem	S.S. 1.4401
06	Stem seal	PTFE+CG
07	Stem packing 1	PTFE+CG
07a	Stem packing 2	Graphite
08	Gland packing 1	S.S. 1.4401
09	Spring washer	S.S. 1.4310
11	Cover	S.S. 1.4408
13	Cover bolt	A4-70
14	Body seal 1	PTFE+CG
15	Body bolt	A2-70
16	Handle	WCB
17	Handle bolt	1.045(8,8)
19	Spring	S.S. 1.4401
20	Antistatic ball	S.S. 1.4401
34	Body seal 2	Graphite
50	Subjection ring	S.S. 1.4301
110	Subjection ring seal	S.S. 1.4401 Nitrided
165	Stem bearing	PTFE+FG

General features

Floating ball.
Split body.
Full bore.
Soft seat.
Bidirectional.
Fire Safe.
TA-LUFT.
Anti Blow out proof stem.
Autoadjustable packing.
Anti static device.
Self-cavity pressure relief.

Standards

Top flange ISO 5211
Flanges EN 1092-01
Face to face EN 558
Testing EN-12266, ISO 5208
Design EN-12516, ISO 17292

Official approvals

CERTIFICATE FIRE SAFE
TÜV.AD-MERKBLATT WO
TA-LUFT
ATEX 94-9EC
PED 97/23/CE.
SIL 3 CAPABLE
EN 161/EN 264

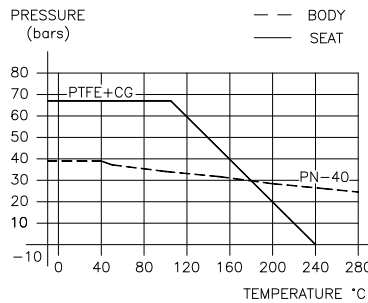

PEKOS GROUP CERTIFICATES:

ISO 9001-2008 / 97-23-CE / API-6D



DIMENSIONS & Technical information

DN	PN	D	L	E	A	B	C	F	H	G	V	X	Y	Z	n x d	ISO 5211	Torque	MAST	Weight
15	40	15	115	95	45	65	16	52	185	100	14	11	11	13,5	4 x 14	F05	14	43,5	3,0
20	40	20	120	105	58	75	18	54	185	102	14	11	11	13,5	4 x 14	F05	16	43,5	3,8
25	40	25	125	115	68	85	18	60	185	110	18	14	17	19,5	4 x 14	F05	20	94,5	4,7
32	40	32	130	140	78	100	18	65	185	115	18	14	17	19,5	4 x 18	F05	34	94,5	6,5
40	40	40	140	150	88	110	18	75	293	129	22	17	20	30	4 x 18	F07	46	250,4	8,2
50	40	50	150	165	102	125	20	83	293	137	22	17	20	30	4 x 18	F07	76	250,4	11,2
65	40	65	170	185	122	145	22	96	293	150	22	17	20	30	8 x 18	F07	98	250,4	16,9
80	40	80	180	200	138	160	24	114	350	187	28	22	22	40	8 x 18	F10	149	522,5	22,2
100	40	100	190	235	162	190	24	128	350	201	28	22	22	40	8 x 22	F10	219	522,5	30,0
125	40	125	325	270	188	220	26	158	680	247	36	27	35	50	8 x 26	F12	396	1073,4	62,0

** Depending on service conditions.

* Dimensions are in mm.

* Torque & MAST are in Nm.

* Weight is in Kilogram

* Torque values have been measured ΔP at maximum rating at room temperature

s

Valve Open - Key Trapped Design

Handle is only removable in the Closed Position

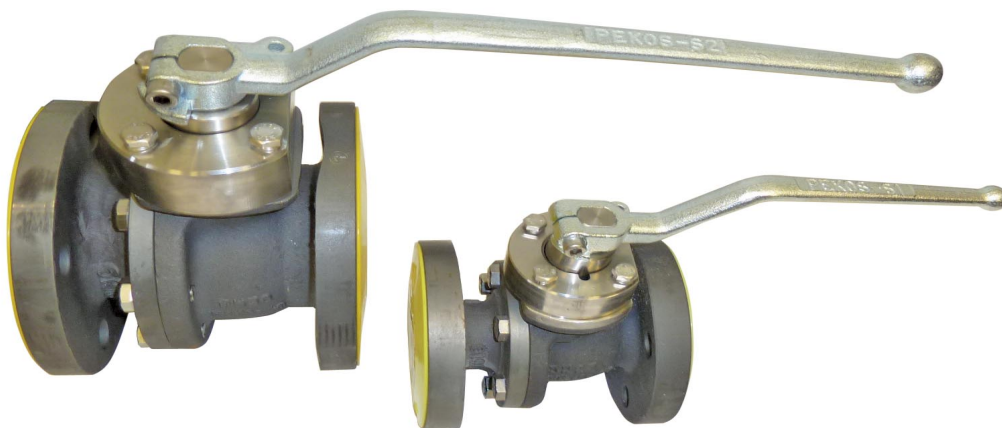
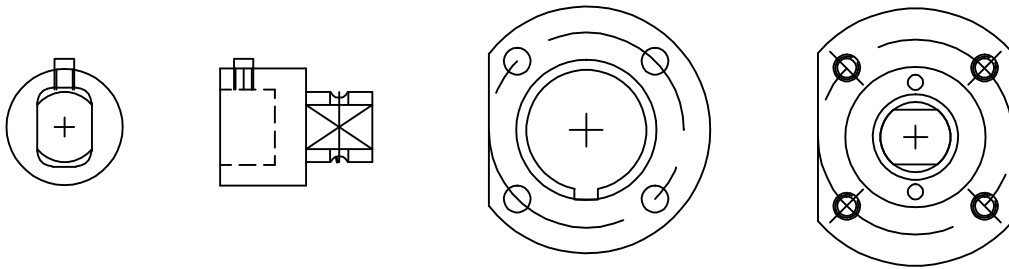

**Also Available with
Pneumatic Actuator**

