

→ Series 642



■ SUITABLE FOR

Liquids	neutral and non-neutral	
Air, gases and vapours	neutral and non-neutral	
Steam		

■ EXAMPLES OF USE

For the protection of:

- Pressure-vessels/-systems for neutral / non-neutral vapours, gases and liquids
- Steam boilers and steam plants taking into account the plant-specific regulations and making use of the suitable valve versions and sealing materials.

- Mechanical engineering
- pump protection
- Pressure booster systems water- / air-side
- cooling-/chilling-systems
- Steam- and industrial-boiler systems

Safety valves are set and sealed at the factory.



■ MATERIAL



■ SPECIFICATION

1/2" – 2 1/2"
 – 50°C to + 205°C depending on version
 0,5 – 16 bar
 DN 25 – DN 65

■ APPROVALS

EC type examination	S/G, L
Type approval WRAS	
Type approval ACS	
TR ZU 032/2013 - TR ZU 010/2011	S/G, L
Requirements	
DIN EN ISO 4126-1 PED 2014/68/EU TRD 421	
Classification society	
DNVGL	DNVGL
Bureau Veritas	BV
Lloyd's Register EMEA	LR EMEA
Russian Maritime Register of Shipping	RS
American Bureau of Shipping	ABS

■ MATERIALS

Component	Material	DIN EN	ASME
Inlet body	Gunmetal	CC499K	CC499K
Outlet body	Gunmetal	CC499K	CC499K
Internal parts	Brass	CW617N	CW617N
Internal wetted parts	Dezincification resistant brass	CW602N	CW602N
Spring	Stainless steel	1.4310	302

■ VALVE VERSION

m	Standard with diaphragm	The diaphragm prevents the medium entering into the spring housing and protects moving parts from being affected by the medium.
----------	-------------------------	---

■ MEDIUM

GF	gaseous and liquid	Air, vapours, gases, liquids and - depending on seal - also for steam
-----------	--------------------	---

■ TYPE OF LIFTING MECHANISM

L	Lifting lever
----------	---------------

■ AVAILABLE NOMINAL DIAMETERS AND CONNECTION SIZES

Nominal diameter DN	15	20	25	32	40	50	65
Inlet	1/2" (15)	3/4" (20)	1" (25)	1 1/4" (32)	1 1/2" (40)	2" (50)	2 1/2" (65)
Outlet	1/2" (15)	■					
	3/4" (20)		■				
	1" (25)			■			
	1 1/4" (32)				■		
	1 1/2" (40)					■	
	2" (50)						■
	2 1/2" (65)						

■ TYPE OF CONNECTION INLET / OUTLET

f / f	Standard	Female thread BSP-P / Female thread BSP-P	DIN EN ISO 228-1 / DIN EN ISO 228-1
Against surcharge			
FLDIN / f		Flange connection (from DN 25) / Female thread BSP-P	DIN EN 1092 / DIN EN ISO 228-1

■ SEAT SEALS / DIAPHRAGMS

PTFE / EPDM	Polytetrafluorethylen / Ethylen-Propylene-Diene (Standard)	Flat seal and moulded diaphragm	-50°C to +205°C
EPDM / EPDM	Ethylen-Propylene-Diene / Ethylen-Propylene-Diene	Flat seal and moulded diaphragm	-50°C bis +150°C
Against surcharge			
PTFE / FKM	Polytetrafluorethylen / Fluorcarbon	Flat seal and moulded diaphragm	-30°C to +200°C
FKM / FKM	Fluorcarbon / Fluorcarbon	Elastomere seals and moulded diaphragm	-20°C to +200°C

■ OPTIONS

Special versions on request.

■ NOMINAL DIAMETERS, CONNECTIONS, INSTALLATION DIMENSIONS

Series 642: Connection, installation dimensions, ranges of adjustment								
Nominal diameter	DN	15	20	25	32	40	50	65
Connection DIN EN ISO 228	G	1/2" (15)	3/4" (20)	1" (25)	1 1/4" (32)	1 1/2" (40)	2" (50)	2 1/2" (65)
Connection DIN EN 1092-3	DN / PN			25 / 16	32 / 16	40 / 16	50 / 16	65 / 16
Connection ANSI B 16.24	NPS / CLASS			1" / 150	1 1/4" / 150	1 1/2" / 150	2" / 150	2 1/2" / 150
Outlet DIN EN ISO 228	G	1/2" (15)	3/4" (20)	1" (25)	1 1/4" (32)	1 1/2" (40)	2" (50)	2 1/2" (65)
Installation dimensions in mm	L	35	42	45	47	58	68	80
	Lmax	63	75	78	100	140	150	155
	H	90	106	120	150	192	229	275
	H1 DIN / ANSI			180 / 180	216 / 216	265 / 265	312 / 312	371 / 371
	Hmax	102	120	133	153	210	252	298
	h	28	36	38	37	45	55	65
	h1 DIN / ANSI			60 / 60	66 / 66	73 / 73	83 / 83	96 / 96
	D DIN / ANSI			115 / 110	140 / 115	150 / 125	165 / 150	185 / 180
	d1 DIN / ANSI			65 / 50,8	76 / 63,5	84 / 73	99 / 92,1	118 / 104,8
	SW	27	34	41	50	60	70	90
	do	13	15	18	23	30	39	48
	K / nxd (DIN)			85 / 4x14	100 / 4x18	110 / 4x18	125 / 4x18	145 / 4x18
	K / nxd (ANSI)			79,4 / 4x15,9	88,9 / 4x15,9	98,4 / 4x15,9	120,7 / 4x19,1	139,7 / 4x19,1
	Weight	kg	0,5	0,8	1,1	1,7	3,3	5,8
Weight	kg FLDIN / FLANSI			2,0 / 1,9	3,4 / 2,9	4,1 / 3,5	8,4 / 7,9	12,0 / 11,8
Range of adjustment	bar	0,5 - 16	0,5 - 16	0,5 - 16	0,5 - 16	0,5 - 16	0,5 - 16	0,5 - 16

■ MAIN DIMENSIONS, INSTALLATION DIMENSIONS

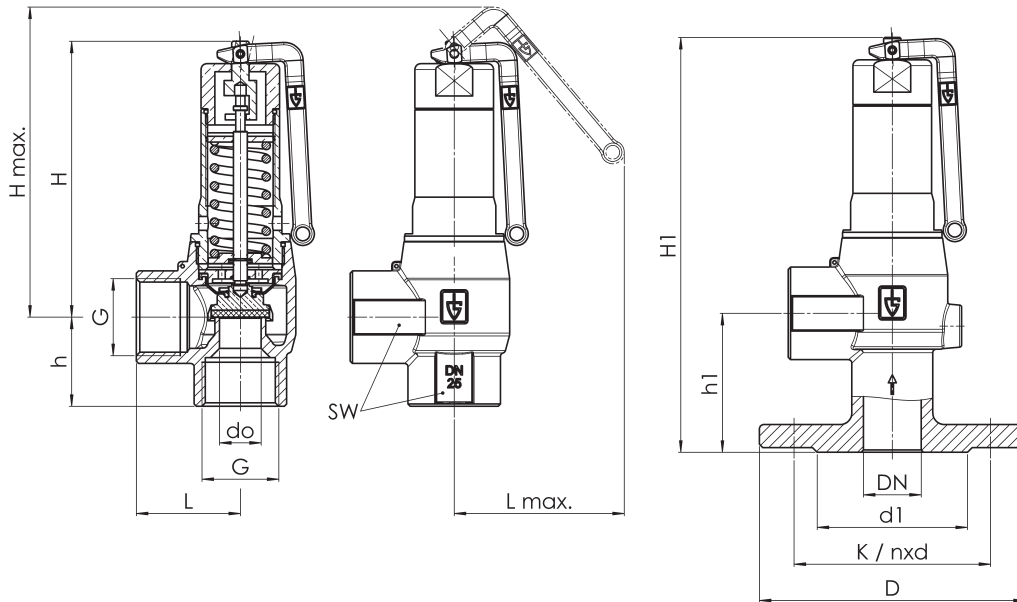

■ INDIVIDUAL SELECTION / VALVE CONFIGURATION

Series	Valve version	Medium	Lifting device	Nominal diameter DN	Connection type		Connection size		Seal / diaphragms	Options	Set pressure	Quantity
					Inlet	Outlet	Inlet	Outlet				
642	m	GF	L	15	f	f	15	15	PTFE/EPDM		6	2
642	m	GF	L	25	f	f	25	25	FKM/FKM		2	4
642	m	GF	L		f	f						
642	m	GF	L		f	f						

In this table you can configure a valve according to your individual requirements (similar to the *example* shown, which should be deleted before you enter your own data). Please complete the table by hand using the abbreviations in this datasheet and then fax it to: +49(0)7141.4889488
Please do not forget to add your personal data so that our sales team can contact you.

Name _____

First Name _____

Company _____

Telephone _____

E-Mail _____

■ CAPACITY TABLE

Series 642: Blowing-off rates at 10% above set pressure																	
Nominal diameter DN		15				20				25				32			
Set pressure bar		I	II	III	IV	I	II	III	IV	I	II	III	IV	I	II	III	IV
Air I Nm ³ /h	0,5	74	56	2,1	36	85	64	2,7	41	105	79	3,4	51	208	157	6,6	101
	1	106	84	2,9	53	124	97	3,7	62	156	123	4,6	78	315	251	8,9	158
	2	173	136	4,1	84	204	159	5,2	98	266	208	6,5	128	525	413	12,6	254
Steam II kg/h	3	233	181	5,0	110	279	217	6,4	131	372	289	8,0	175	729	570	15,4	344
	4	293	226	5,8	135	357	276	7,4	164	477	368	9,2	219	916	710	17,7	423
	5	352	272	6,5	159	438	338	8,2	198	574	443	10,3	260	1103	851	19,8	500
Water III m ³ /h	6	412	318	7,1	184	512	395	9,0	228	671	518	11,3	299	1289	992	21,7	576
	7	471	364	7,7	207	586	452	9,7	258	768	593	12,2	338	1476	1130	23,5	650
	8	531	410	8,2	231	660	509	10,4	287	865	668	13,1	376	1662	1269	25,1	724
Heating IV kW	9	591	456	8,7	254	734	566	11,0	315	963	743	13,9	414	1849	1408	26,6	795
	10	650	502	9,2	276	808	623	11,6	344	1060	818	14,6	451	2036	1546	28,1	865
	11	710	548	9,6	299	882	680	12,2	372	1157	892	15,3	487	2222	1683	29,4	938
	12	770	594	10,1	321	956	738	12,7	399	1254	967	16,0	523	2409	1820	30,7	1008
	13	829	640	10,5	343	1030	795	13,3	426	1351	1042	16,7	559	2595	1958	32,0	1078
	14	889	686	10,9	365	1104	852	13,8	453	1448	1117	17,3	594	2782	2097	33,2	1145
	15	948	732	11,3	386	1178	909	14,3	480	1545	1192	17,9	629	2969	2234	34,4	1213
	16	1008	778	11,6	407	1252	966	14,7	506	1643	1267	18,5	664	3155	2372	35,5	1282

Series 642: Blowing-off rates at 10% above set pressure													
Nominal diameter DN		40				50				65			
Set pressure bar		I	II	III	IV	I	II	III	IV	I	II	III	IV
Air I Nm ³ /h	0,5	285	215	9,2	138	494	372	15,5	239	729	549	23,6	352
	1	414	331	12,5	208	700	559	21,1	352	1034	826	31,9	520
	2	677	534	17,6	327	1145	902	29,8	553	1734	1366	45,1	838
Steam II kg/h	3	931	728	21,6	439	1573	1230	36,5	741	2383	1862	55,2	1123
	4	1169	906	24,9	540	1975	1532	42,1	913	2992	2320	63,8	1383
	5	1407	1085	27,9	638	2378	1834	47,1	1078	3602	2778	71,3	1633
Water III m ³ /h	6	1645	1266	30,5	736	2780	2139	51,6	1243	4211	3240	78,1	1883
	7	1883	1441	33,0	830	3182	2436	55,7	1403	4821	3690	84,4	2125
	8	2121	1619	35,2	924	3585	2737	59,5	1561	5430	4146	90,2	2365
Heating IV kW	9	2359	1796	37,4	1014	3987	3036	63,2	1713	6040	4599	95,7	2595
	10	2597	1973	39,4	1104	4389	3334	66,6	1866	6649	5050	100,8	2827
	11	2835	2148	41,3	1197	4792	3630	69,8	2023	7259	5499	105,8	3065
	12	3074	2322	43,1	1286	5194	3925	72,9	2173	7868	5945	110,5	3291
	13	3312	2498	44,9	1376	5597	4222	75,9	2325	8478	6396	115,0	3522
	14	3550	2675	46,6	1461	5999	4521	78,8	2468	9087	6848	119,3	3739
	15	3788	2850	48,2	1548	6401	4817	81,5	2616	9697	7297	123,5	3962
	16	4026	3026	49,8	1635	6804	5114	84,2	2764	10306	7747	127,6	4187

