



SQM5 gear side with drive shaft no. 7



SQM5 rear side, design without a second drive shaft end



SQM5 rear side, design with 2 drive shaft ends

Actuators for Air and Gas Dampers

SQM5...

with electronic modules

- Electromotive actuator with up to 40 Nm torque
- Clockwise and counterclockwise variants
- Running times from 10 to 90 seconds
- Different shaft designs available
- With 1 or 2 drive shaft ends, drive shafts interchangeable or available separately
- Can be equipped with electronic modules for control and position feedback signal via steady signals
- Internal and external position indication
- Drive shaft and camshaft can be disengaged separately
- Variants with UL certification

The SQM5... and this Data Sheet are intended for use by OEMs which integrate the SQM5... in their products!

Use

The SQM5 actuators are designed to drive air and gas dampers. Areas of application are oil and gas burners of medium to larger capacity.

The actuators are used primarily for the load-dependent control of the gas flow, oil volume and combustion air volume:

- In connection with 3-position or modulating controllers (e.g. 4...20 mA), and/or
- Directly by burner controls

Supplementary documentation

Product type	Type of documentation	Documentation number
ASZ...	Data sheet	N7921
AGA56...	Data sheet	N7922

Warning notes



To avoid injury to persons, damage to property or the environment, the following warning notes must be observed!

Only qualified staff may open, interfere with or modify the actuators!

- Read the documentation on the actuators carefully and fully. If not observed, dangerous situations can occur
- The user must ensure that the actuators meet the requirements of the relevant application standards
- All product-related activities (mounting, settings and maintenance) must be performed by qualified and authorized personnel



Caution!

- Risk of electric shock – to disconnect the equipment from the power, it may be necessary to open more than one switch. Before performing maintenance work, the equipment must be disconnected from the power supply
 - The electrical connection between the conduit fittings is not made automatically. It must be established on the installation site
 - The connecting plate is made of plastic and does not provide earthing of the conduit fittings. Earthing must be ensured by adequate washers and wire links
 - All cam switch settings must satisfy the requirements of the relevant application standards
-
- To ensure protection against electric shock, the connection terminals must have adequate protection. Make certain that non-insulated connections or wires cannot be touched
 - Each time work has been carried out (mounting, installation, service work, etc.), check to ensure that wiring is in an orderly state
 - Fall or shock can adversely affect the safety functions. Such actuators must not be put into operation even if they do not exhibit any damage
 - Static charges must be avoided since they can damage the electronic components on contact.

Recommendation: Use ESD equipment

Notes on use in North America

- Only flexible conduits with relevant accessories may be used
- Only copper conductors may be used
- All Class 2 circuits must be wired with CL3, CL3R, CL3P or equivalent cables
OR
All circuits are wired according to Class 1 (electric light or power circuits)

Mounting notes

- Ensure that the relevant national safety regulations are complied with
- In the geographical areas where DIN regulations are in use, the requirements of VDE must be complied with, especially DIN/VDE 0100, 0550 and DIN/VDE 0722
- Make certain that the actuator is not exposed to direct solar radiation
- Tightening torques
 - Cover screws: 3.5 Nm
 - Connecting cover: 2 Nm

Installation notes

- Ensure that the electrical wiring is in compliance with national and local regulations
- Make certain that strain relief of the connected cables is in compliance with the relevant standards (e.g. in accordance with DIN EN 60730 and DIN EN 60335)
- Ensure that spliced wires cannot come into contact with neighboring terminals. Use suitable ferrules
- SQM5 terminals that are not used must be protected by dummy plugs
- When wiring the unit, separation between the 120 V AC or 230 V AC range and the other voltage ranges must be maintained in order to ensure protection against electric shock
- The connection between the actuator drive shaft and the relevant controlling element must be form-fitted
- Only plastic versions of cable glands may be used

Standards and certificates



Applied directives:

- Low-voltage directive 2014/35/EC
- Electromagnetic compatibility EMC (immunity) 2014/30/EC

Compliance with the regulations of the applied directives is verified by the adherence to the following standards / regulations:

- Automatic electrical controls for household and similar use Part 1: General requirements DIN EN 60730-1
- Automatic electrical controls for household and similar use Part 2-14: Particular requirements for electric actuators DIN EN 60730-2-14

The relevant valid edition of the standards can be found in the declaration of conformity!



EAC Conformity mark (Eurasian Conformity mark)



ISO 9001:2015
ISO 14001:2015
OHSAS 18001:2007



China RoHS
Hazardous substances table:
<http://www.siemens.com/download?A6V10883536>



For use in the U.S. / Canada, the actuators carry type suffix «R» (see example) and are

UL- and CSA-listed.

Example: SQM50.480**R**1

Lifetime

The actuator has a designed lifetime* of 250,000 burner startup cycles (OFF ⇒ ON ⇒ OFF) under load with the rated torque in the entire rotation angle range, which under normal operating conditions in heating mode corresponds to approx. 10 years of service (starting from the production date given on the nameplate). This is based on the endurance tests specified in the standard EN 298.

A summary of the conditions has been published by the European Control Manufacturers Association (Afecor) (www.afecor.org).

The lifetime is based on use of the actuator according to the manufacturer's data sheet. After reaching the designed lifetime in terms of the number of burner startup cycles, or after the corresponding usage time, the actuator must be replaced by authorized personnel.

*The designed lifetime is not the warranty time specified in the Terms of Delivery

Disposal notes

The actuator contains electrical and electronic components and must not be disposed of together with domestic waste.

Local and currently valid legislation must be observed.

Mechanical design

- | | |
|-------------|---|
| Housing | <ul style="list-style-type: none"> • Housing sections made of die-cast aluminium • Covers made of impact-proof and heat-resistant plastic |
| Drive motor | <ul style="list-style-type: none"> • Synchronous motor |
| Couplings | <ul style="list-style-type: none"> • Driven shaft and cam shaft can be adjusted via 2 separately couplers, independent of the gear train • Shaft can be manually disengaged from the gear and motor by operating the coupling (coupling pin (Kx), refer to <i>Technical data</i>) • Automatic reengagement • Coupling pin (K1 and K2) |

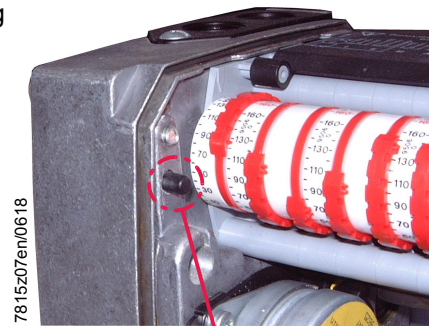

Coupling pin "K1"

- Separation of drive shaft and gear using coupling pin (K2)

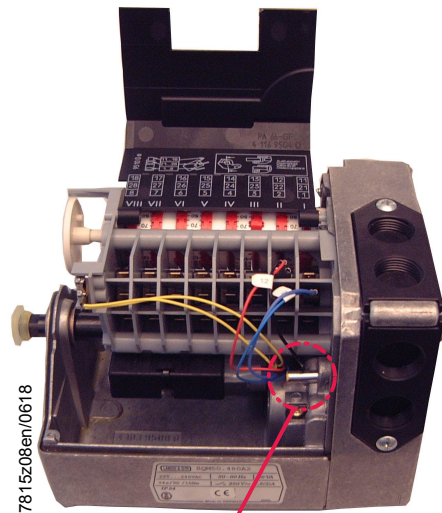

Coupling pin "K2"

- | | |
|--------------------------------|---|
| Cam shaft drive | <ul style="list-style-type: none"> • Backlash-free gearing |
| Adjustment of switching points | <ul style="list-style-type: none"> • Via rotating cams • Scales adjacent to the cams indicate the angle of the switching point |
| Position indication | <ul style="list-style-type: none"> • Internally: <ul style="list-style-type: none"> – Scale at the end of the drive shaft – Black scale for counterclockwise rotation, single arrow on the cam – Red scale for clockwise rotation, double arrow on the cam • Externally: <ul style="list-style-type: none"> – Scale in viewing window |

Mechanical design (cont'd)

- | | |
|------------------------|---|
| Electrical connections | <ul style="list-style-type: none">• Blade terminal on micro switch• Screw terminals for «N» and «PE»• Subassembly and fixing of wiring by means of removable Pg plastic insert possible• Easy introduction of cables through large openings in the housing• Fixing of Pg insert with all cables by means of a screw |
| Gear train | <ul style="list-style-type: none">• Maintenance-free gearwheels and bearings |
| Drive shaft | <ul style="list-style-type: none">• Secured with a removable circlip• Easily exchangeable• With corresponding shaft both sides transmission possible• Different shaft designs available |
| Actuator fixing | <ul style="list-style-type: none">• Fixing holes on the front of the housing and at the bottom• Front fixing also possible from inside the housing• Variable mounting height through the use of an extra adapter |

Type summary (other types are available on request)

Actuators with premounted accessories are only available on request.

AC 220 V -15% ... AC 240 V +10%, 50...60 Hz ±6%

Standard types! (other versions on request)		Torque and holding torque 3)	Running time at 50 Hz for angular rotation 1)		Auxiliary switches incl. 2 end switches	Type of shaft	Electronic module (integrated ex works) 5)	Potentiometer (integrated ex works) 6)
Article no.	Type	Max. Nm 2)	90°	130°	Piece	AGA...	AGA...	ASZ...
BPZ:SQM50.260A2G4	SQM50.260A2G4	10	10 s	14 s	4	---	56.41A27	12.33
S55452-D401-A100	SQM50.260A2Z3	10	10 s	14 s	4	---	56.9Ax7	12.30
BPZ:SQM50.341A2	SQM50.341A2	10	15 s	22 s	4	58.1	---	---
BPZ:SQM50.341A2G3	SQM50.341A2G3	10	15 s	---	4	58.1	56.41A27	12.30
BPZ:SQM50.341A2K3	SQM50.341A2K3	10	15 s	---	4	58.1	56.43A27	12.30
BPZ:SQM50.380A2	SQM50.380A2	15	15 s	22 s	8	---	---	---
BPZ:SQM50.381A2	SQM50.381A2	10	15 s	22 s	8	58.1	---	---
BPZ:SQM50.381A2G3	SQM50.381A2G3	10	15 s	---	8	58.1	56.41A27	12.30
BPZ:SQM50.387A2	SQM50.387A2	15	15 s	22 s	8	58.7	---	---
BPZ:SQM50.387A2G3	SQM50.387A2G3	15	15 s	---	8	58.7	56.41A27	12.30
BPZ:SQM50.424A2Z7	SQM50.424A2Z7	15	34 s	---	2	58.4	56.9A27	12.30
BPZ:SQM50.441A2	SQM50.441A2	10	34 s	49 s	4	58.1	---	---
BPZ:SQM50.441A2G3	SQM50.441A2G3	10	34 s	---	4	58.1	56.41A27	12.30
BPZ:SQM50.441A2Z3	SQM50.441A2Z3	10	34 s	---	4	58.1	56.9A27	12.30
BPZ:SQM50.480A2	SQM50.480A2	15	34 s	49 s	8	---	---	---
BPZ:SQM50.480A2G3	SQM50.480A2G3	15	34 s	---	8	---	56.41A27	12.30
BPZ:SQM50.480A2Z3	SQM50.480A2Z3	15	34 s	---	8	---	56.9A27	12.30
BPZ:SQM50.481A2	SQM50.481A2	10	34 s	49 s	8	58.1	---	---
BPZ:SQM50.481A2G3	SQM50.481A2G3	10	34 s	---	8	58.1	56.41A27	12.30
BPZ:SQM50.481A2Z3	SQM50.481A2Z3	10	34 s	---	8	58.1	56.9A27	12.30
BPZ:SQM50.482A2	SQM50.482A2	15	34 s	49 s	8	58.2	---	---
BPZ:SQM50.482A2Z3	SQM50.482A2Z3	15	34 s	---	8	58.2	56.9A27	12.30

Standard types! (other versions on request)		Torque and holding torque 3)	Running time at 50 Hz for angular rotation 1)		Auxiliary switches incl. 2 end switches	Type of shaft	Electronic module (integrated ex works) 5)	Potentiometer (integrated ex works) 6)
Article no.	Type	Max. Nm 2)	90°	130°	Piece	AGA...	AGA...	ASZ...
BPZ:SQM50.483A2	SQM50.483A2	15	34 s	49 s	8	58.3	---	---
BPZ:SQM50.483A2Z3	SQM50.483A2Z3	15	30 s	43 s	8	58.3	56.9A27	12.30
BPZ:SQM50.681A2	SQM50.681A2	10	68 s	98 s	8	58.1	---	---
BPZ:SQM53.442A2	SQM53.442A2	25	30 s	43 s	4	58.2	---	---
BPZ:SQM53.482A2	SQM53.482A2	20	30 s	43 s	8	58.2	---	---
BPZ:SQM53.482A2G4	SQM53.482A2G4	20	30 s	---	8	58.2	56.41A27	12.33
BPZ:SQM53.482A2Z3	SQM53.482A2Z3	20	30 s	---	8	58.2	56.9A27	12.30
BPZ:SQM53.489A2	SQM53.489A2	25	30 s	43 s	8	58.9	---	---
BPZ:SQM53.582A2	SQM53.582A2	20	45 s	65 s	8	58.2	---	---
BPZ:SQM54.480A2	SQM54.480A2	25	30 s	43 s	8	---	---	---
BPZ:SQM54.482A2	SQM54.482A2	20	30 s	43 s	8	58.2	---	---
BPZ:SQM54.482A2Z3	SQM54.482A2Z3	20	30 s	43 s	8	58.2	56.9A27	12.30
BPZ:SQM54.580A2	SQM54.580A2	25	45 s	65 s	8	---	---	---
BPZ:SQM56.680A2	SQM56.680A2	40	60 s	87 s	8	---	---	---
BPZ:SQM56.684A2G4	SQM56.684A2G4	30	60 s	87 s	8	58.4	56.41A27	12.33
BPZ:SQM56.684A2Z3	SQM56.684A2Z3	30	60 s	---	8	58.4	56.9A27	12.30
BPZ:SQM56.687A2	SQM56.687A2	40	60 s	87 s	8	58.7	---	---
BPZ:SQM56.687A2G3	SQM56.687A2G3	40	60 s	---	8	58.7	56.41A27	12.30
BPZ:SQM56.687A2Z3	SQM56.687A2Z3	40	60 s	---	8	58.7	56.9A27	12.30

Type summary (other types are available on request)

AC 110 V -15%/+10%, 50...60 Hz ±6%

Standard types! (other versions on request)		Torque and holding torque 3)	Running time at 50 Hz for angular rotation 1)		Auxiliary switches incl. 2 end switches	Type of shaft	Electronic module (integrated ex works) 5)	Potentiometer (integrated ex works) 6)
Article no.	Type	Max. Nm 2)	90°	130°	Piece	AGA...	AGA...	ASZ...
BPZ:SQM50.380A1	SQM50.380A1	10	15 s	22 s	8	--- ⁴⁾	---	---
BPZ:SQM50.454A1	SQM50.454A1	15	34 s	49 s	5	58.4	---	---
BPZ:SQM50.480A1	SQM50.480A1	15	34 s	49 s	8	--- ⁴⁾	---	---
BPZ:SQM50.480A1Z3	SQM50.480A1Z3	15	34 s	---	8	--- ⁴⁾	56.9A17	12.30
BPZ:SQM50.483A1Z3	SQM50.483A1Z3	15	30 s	---	8	58.3	56.9A17	12.30
BPZ:SQM50.680A1	SQM50.680A1	15	68 s	98 s	8	--- ⁴⁾	---	---
BPZ:SQM53.480A1	SQM53.480A1	25	30 s	43 s	8	--- ⁴⁾	---	---
BPZ:SQM53.482A1	SQM53.482A1	20	30 s	43 s	8	58.2	---	---
BPZ:SQM53.482A1Z3	SQM53.482A1Z3	20	30 s	---	8	58.2	56.9A17	12.30
BPZ:SQM53.580A1	SQM53.580A1	25	45 s	65 s	8	--- ⁴⁾	---	---
BPZ:SQM54.482A1	SQM54.482A1	20	30 s	43 s	8	58.2	---	---
BPZ:SQM56.680A1	SQM56.680A1	40	60 s	87 s	8	--- ⁴⁾	---	---
BPZ:SQM56.687A1	SQM56.687A1	40	60 s	87 s	8	58.7	---	---
BPZ:SQM56.687A1Z3	SQM56.687A1Z3	40	60 s	---	8	58.7	56.9A17	12.30

Type summary (other types are available on request)

AC 24 V -15/+10%, 50...60 Hz ±6%

Standard types! (other versions on request)		Torque and holding torque 3)	Running time at 50 Hz for angular rotation 1)		Auxiliary switches incl. 2 end switches	Type of shaft	Electronic module (integrated ex works) 5)	Potentiometer (integrated ex works) 6)
Article no.	Type	Max. Nm 2)	90°	130°	Piece	AGA...	AGA...	ASZ...
BPZ:SQM50.380A8	SQM50.380A8	15	15 s	22 s	8	--- ⁴⁾	---	---
BPZ:SQM50.454A8	SQM50.454A8	15	34 s	49 s	5	58.4	---	---
BPZ:SQM50.480A8	SQM50.480A8	15	34 s	49 s	8	--- ⁴⁾	---	---
BPZ:SQM50.480A8Z3	SQM50.480A8Z3	15	34 s	---	8	--- ⁴⁾	56.9A87	12.30
BPZ:SQM50.483A8	SQM50.483A8	15	34 s	49 s	8	58.3	---	---
BPZ:SQM50.483A8Z3	SQM50.483A8Z3	15	34 s	---	8	58.3	56.9A87	12.30
BPZ:SQM50.543A8	SQM50.543A8	15	45 s	65 s	4	58.3	---	---
BPZ:SQM50.680A8	SQM50.680A8	15	60 s	87 s	8	--- ⁴⁾	---	---
BPZ:SQM53.480A8	SQM53.480A8	25	30 s	43 s	8	--- ⁴⁾	---	---
BPZ:SQM56.687A8	SQM56.687A8	40	60 s	87 s	8	58.7	---	---

Type summary (other types are available on request)

AC 110 V -15%/+10%, 60 Hz ±6%, UL-registered

Standard types! (other versions on request)		Torque and holding torque 3)	Running time at 50 Hz for angular rotation 1)		Auxiliary switches incl. 2 end switches	Type of shaft	Electronic module (integrated ex works) 5)	Potentiometer (integrated ex works) 6)
Article no.	Type	Max. Nm 2)	90°	130°	Piece	AGA...	AGA...	ASZ...
BPZ:SQM50.260R1	SQM50.260R1	15	8 s	12 s	6	---	---	---
BPZ:SQM50.260R1G4	SQM50.260R1G4	15	8 s	12 s	6	---	56.41A17	12.33
BPZ:SQM50.360R1	SQM50.360R1	15	12 s	18 s	6	---	---	---
BPZ:SQM50.361R1G3	SQM50.361R1G3	10	12 s	---	6	58.1	56.41A17	12.30
BPZ:SQM50.361R1G4	SQM50.361R1G4	10	12 s	18 s	6	58.1	56.41A17	12.33
BPZ:SQM50.364R1G3	SQM50.364R1G3	15	12 s	---	6	58.4	56.41A17	12.30
BPZ:SQM50.367R1G3	SQM50.367R1G3	10	12 s	---	6	58.7	56.41A17	12.30
BPZ:SQM50.450R1G3	SQM50.450R1G3	15	28 s	---	5	---	56.41A17	12.30
BPZ:SQM50.460R1	SQM50.460R1	15	28 s	41 s	6	---	---	---
BPZ:SQM50.464R1G3R	SQM50.464R1G3R	15	34 s	---	6	58.4	56.41A17	12.30
BPZ:SQM50.480R1	SQM50.480R1	15	28 s	41 s	8	---	---	---
BPZ:SQM50.480R1Z3	SQM50.480R1Z3	15	28 s	---	8	---	56.9A17	12.30
BPZ:SQM50.481R1	SQM50.481R1	10	28 s	41 s	8	58.1	---	---
BPZ:SQM53.460R1	SQM53.460R1	25	28 s	36 s	6	---	---	---
BPZ:SQM53.480R1G3	SQM53.480R1G3	25	28 s	---	8	---	56.41A17	12.30
BPZ:SQM53.480R1Z3	SQM53.480R1Z3	25	28 s	---	8	---	56.9A17	12.30
BPZ:SQM54.560R1	SQM54.560R1	25	27 s	54 s	6	---	---	---
BPZ:SQM54.560R1A	SQM54.560R1A	25	37 s	54 s	6	---	56.1A97	---
BPZ:SQM56.560R1	SQM56.560R1	40	37 s	54 s	6	---	---	---
BPZ:SQM56.560R1G4	SQM56.560R1G4	40	37 s	54 s	6	58.1	56.41A17	12.33
BPZ:SQM56.660R1	SQM56.660R1	40	50 s	72 s	6	---	---	---

Standard types! (other versions on request)		Torque and holding torque 3)	Running time at 50 Hz for angular rotation 1)		Auxiliary switches incl. 2 end switches	Type of shaft	Electronic module (integrated ex works) 5)	Potentiometer (integrated ex works) 6)
Article no.	Type	Max. Nm 2)	90°	130°	Piece	AGA...	AGA...	ASZ...
BPZ:SQM56.680R1G3	SQM56.680R1G3	40	50 s	---	8	--- 4)	56.41A17	12.30
BPZ:SQM56.680R1Z3	SQM56.680R1Z3	40	50 s	---	8	--- 4)	56.9A17	12.803
BPZ:SQM56.687R1	SQM56.687R1	40	50 s	87 s	8	58.7	---	---

Type summary (other types are available on request)

AC 24 V -15/+10%, 50...60 Hz ±6%, UL-registered

Standard types! (other versions on request)		Torque and holding torque 3)	Running time at 50 Hz for angular rotation 1)		Auxiliary switches incl. 2 end switches	Type of shaft	Electronic module (integrated ex works) 5)	Potentiometer (integrated ex works) 6)
Article no.	Type	Max. Nm 2)	90°	130°	Piece	AGA...	AGA...	ASZ...
BPZ:SQM50.450R8G3	SQM50.450R8G3	15	34 s	---	5	--- 4)	56.41A87	12.30
BPZ:SQM50.460R8	SQM50.460R8	15	34 s	49 s	6	--- 4)	56.41A87	---

The actuators are

- also meet CE requirements
- are of the same basic design as the equivalent standard types

- 1) At 60 Hz frequency, running times are about 17 % shorter
- 2) Based on 250,000 position changes
- 3) See drive shafts and torques depending on the voltage
- 4) Order drive shaft separately
- 5) For details, refer to Data Sheet N7922
- 6) For details, refer to Data Sheet N7921

Accessories (must be ordered separately)



Proportional controlling element with mounting plate **VKP**

- Proportional controlling element for mounting between threaded flanges in gas trains
- Refer to Data Sheet N7632.



Mounting plate **ASK33.3**

Article no.: **BPZ:ASK33.3**

- For mounting the SQM5 onto the VKP proportional controlling element using only the AGA58.5 drive shaft.
- Refer to Mounting Instruction 74 319 0843 0 (M7646)



Mounting kit **ASK33.9**

Article no.: **BPZ:ASK33.9**

- For mounting the SQM5 onto butterfly valve VKF41.xxxC using only the AGA58.1 drive shaft
- Refer to Mounting Instruction 4 319 9535 0 (M7815.4)



Pg insert **AGA55.2**

Article no.: **BPZ:AGA55.2**

Inclusive sealing and screw, for SQM5.



Kit for shaft seal **AGA55.5**

Article no.: **BPZ:AGA55.5**



- For sealing the shaft feed through and therewith for perfecting the degree of protection
- On both sides shaft seals for actuator SQM5
- Packed as kit together with O-rings inclusive mounting screws
- Refer to Mounting Instruction M7815.5 (74 319 0577 0)



Spacer **AGA57.1**

Article no.: **BPZ:AGA57.1**

- Adapter for SQM10 / SQM20
- Refer to Mounting Instruction M7815.1 (4 319 9529 0)

Auxiliary (must be ordered separately) (continued)



Adapter for actuator ME8 **AGA57.2**
Article no.: **BPZ:AGA57.2**

Refer to Mounting Instruction M7815.2 (4 319 9536 0).



Adapter for Honeywell Mod. III actuator **AGA57.3**
Article no.: **BPZ:AGA57.3**

Refer to Mounting Instruction M7815.2 (4 319 9536 0).

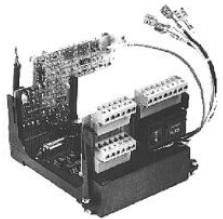

Electronic modules **AGA56**

- For control of the actuator
- Modular installable, complete with mounting frame and fixing screws
- See for **AGA56.1x** Data Sheet N7922 and Mounting Instruction M7922.3 (4 319 9602 0)
- See for **AGA56.4x** Data Sheet N7922 and Mounting Instruction M7922.2 (4 319 9542 0)
- See for **AGA56.9x** Data Sheet N7922 and Mounting Instruction M7922.1 (4 319 9532 0)



Potentiometers **ASZ**

- **ASZxx.3x** refer to Mounting Instruction M7921 (4 319 9604 0)
- **ASZxx.7xx** refer to Mounting Instruction M7806/M7808/M7812 (4 319 2263 0)
- **ASZxx.8xx** refer to Mounting Instruction M7806/M7808/M7812 (4 319 2263 0)
- **ASZxx.9xx** refer to Mounting Instruction M7806/M7808/M7812 (4 319 2263 0)
- Refer to Data Sheet N7921

Auxiliary (must be ordered separately) (continued)



Drive shafts	Max. torque	Type no.	Order no.	
			Article no.	Type
10 mm dia., single-sided , Woodruff key to DIN 6888, equivalent to drive shaft of SQM10...	10 Nm	1	BPZ:AGA58.1	AGA58.1
10 mm dia., single-sided , Woodruff key to DIN 6888, equivalent to drive shaft of SQM10..., packs of 10 pieces	10 Nm	1	BPZ:AGA58.1(10)	AGA58.1(10)
12 mm dia., single-sided , Woodruff key to DIN 6888, equivalent to drive shaft of SQM20...	20 Nm	2	BPZ:AGA58.2	AGA58.2
9 mm square, double-sided , equivalent to drive shaft of ME8	25 Nm	3	BPZ:AGA58.3	AGA58.3
9.5 mm square, double-sided , equivalent to drive shaft of Honeywell Mod. III	30 Nm	4	BPZ:AGA58.4	AGA58.4
9.5 mm square, double-sided , equivalent to drive shaft of Honeywell Mod. III, packs of 10 pieces	30 Nm	4	BPZ:AGA58.4(10)	AGA58.4(10)
Ø 10 mm on one side, D-shaped shaft end	10 Nm	5	BPZ:AGA58.5	AGA58.5
Ø 10 mm gear side, Ø 9.5 mm rear side , DIN 6888 Woodruff key, corresponds to shaft on Honeywell Mod. SQM10	10 Nm	6	BPZ:AGA58.6	AGA58.6
14 mm dia., single-sided with parallel key to DIN 6885, mandatory with SQM56...	40 Nm	7	BPZ:AGA58.7	AGA58.7
14 mm dia., single-sided with parallel key to DIN 6885, mandatory with SQM56..., packs of 10 pieces	40 Nm	7	BPZ:AGA58.7(10)	AGA58.7(10)
12 mm square, single-sided	30 Nm	9	BPZ:AGA58.9	AGA58.9

Refer to Mounting Instruction M7815.3 (4 319 9534 0).

Technical data

General unit data	Kind of current	AC
	Operating voltage and operating frequency	Refer to «Type summary»
	Drive motor	Synchronous motor
	Power consumption	20 VA
	Angular rotation	Between 0° and max. 160° (scale range)
	Mounting position	Optional
	Degree of protection	IP54 (provided knockout holes remain closed for mounting or are closed off, with adequate cable entries)
	Safety class	I
	External overload fuse	Max. 6.3 AT (slow), to DIN EN 60127-2/5
	Internal overload fuse	Max. 2 AT (slow), depending on the type
	Cable entry	4 x Pg13.5 with thread
	Wire cross-sectional area of the connecting wires, including earth terminal (PE)	0.5...2.5 mm ²
	Direction of rotation	Facing the gear train side: counterclockwise or clockwise (selectable), delivery: counterclockwise
	Torque	See the <i>Torques</i> diagram and <i>Drive shafts</i> accessories
	Holding torque	Max. torque
	Running time	10...90 s (refer to «Type summary») ¹⁾
	Pause time at change in direction of rotation	> 100 ms
	End and auxiliary switches	
	- Type	To DIN 41636
	- Switching voltage	AC 24...250 V
	- Switching capacity	To CEE 24 / VDE 0630 7.5 (3) A, AC 250 V
	Number of end switches	2
	Number of auxiliary switches	Max. 6, depending on the type
Drive shaft	Replaceable	
Weight	Approx. 3.3 kg	
Temperature of the mounting surface	Max. 60 °C	
Lifecycle	250,000 start cycles (OFF ⇔ ON ⇔ OFF) under load with the rated torque in the entire rotation angle range. 2,000,000 control cycles under load with 75% of rated torque in rotation angle range of 10°	

- 1) Specifications apply to ambient temperatures of 23 °C and a mains voltage of 120 V AC or 230 V AC and a mains frequency of 50 Hz. With a mains frequency of 60 Hz, the running times are approx. 20% shorter.
Torques lower by the same rate.

Technical data (cont'd)

Environmental conditions	Storage	DIN EN 60721-3-1
	Climatic conditions	Class 1K2
	Mechanical conditions	Class 1M2
	Temperature range without integrated AGA56...	-50...+60 °C
	Humidity	<95 % r.h.
	Transport	DIN EN 60721-3-2
	Climatic conditions	Class 2K2
	Mechanical conditions	Class 2M2
	Temperature range without integrated AGA56...	-50...+60 °C
	Humidity	<95 % r.h.
	Operation	DIN EN 60721-3-3
	Climatic conditions	Class 3K3
	Mechanical conditions	Class 3M3
	Temperature range without integrated AGA56...	-20...+60 °C
	Humidity	<95 % r.h.
Installation altitude	Max. 2,000 m above sea level	



Caution!

Condensation, formation of ice and ingress of water are not permitted!
Failure to observe this poses a risk of damaging the safety functions and the risk of electric shock.

Technical data (cont'd)

Conductive plastic potentiometer	Resistance	2*1000 Ω double potentiometer Maximum rotation angle, depending on the type
	Operating voltage	10 V DC
	Permissible hysteresis	0.3% of 90° or of 135°, depending on the type
	Total resistance tolerance	$\pm 20\%$
	Effective rotation angle	90° or 135°
	Connection terminal strip	3-pole
	For a wire cross-section of ...	0.5...1 mm ²
	Wiper current rating	Max. 100 μ A
	Transfer resistance of the wiper contact	Max. $R_{ü} \leq 100 \Omega$
	Linearity (based on $R_{ges} = 1000 \Omega$)	$\pm 1\%$
	Sleekness ($\alpha = 10^\circ$) / microlinearity	< 0.5%
	Lifetime	Approx. 2 million actuation cycles

Connection diagram

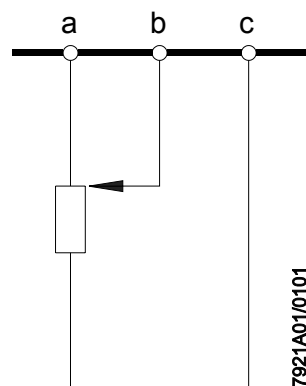

Potentiometer displayed in start position.

Terminal markings:

a = pickup at end of potentiometer

b = potentiometer wiper

c = pickup at end of potentiometer

Apply operating voltage to «a» and «c».

Conductive plastic potentiometers can be destroyed if operating voltage is applied between «a → b» or «b → c».

Torques

SQM50...

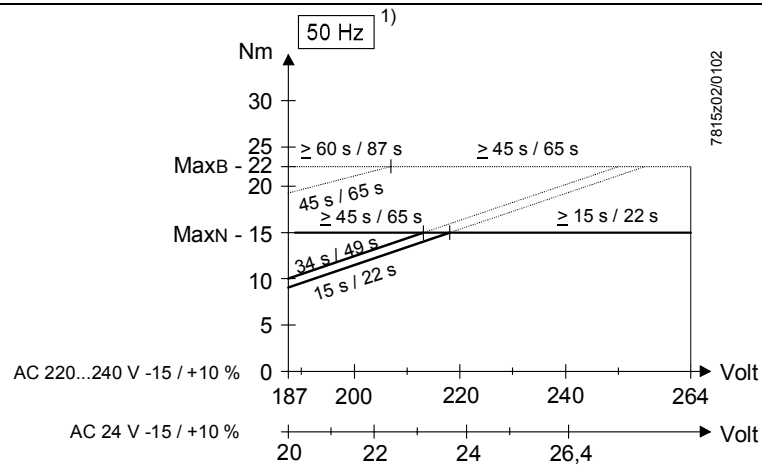

SQM53... / SQM54...

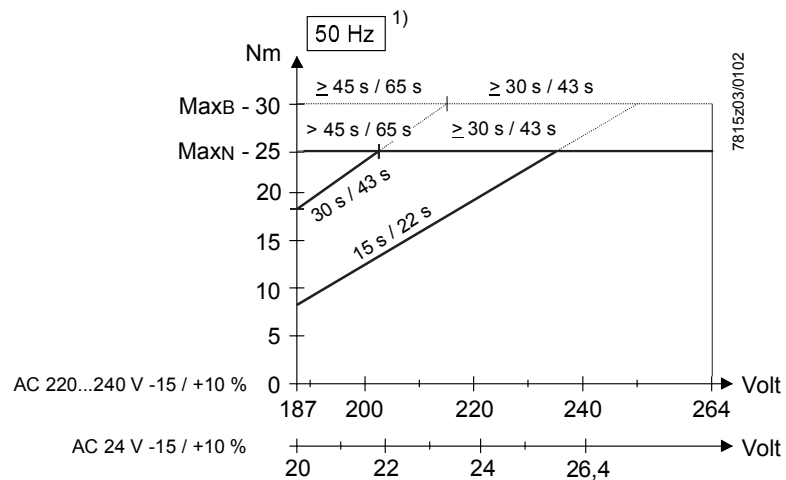

SQM56...

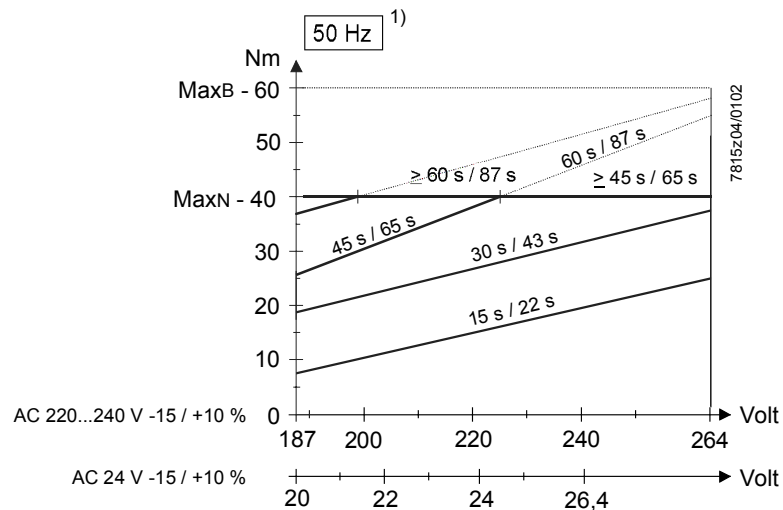

Legend

1) At 60 Hz frequency, running times are about 17 % shorter and torques are proportionally lower



Note!

Each drive side is capable of delivering the maximum torque, but the total torque of both sides must not exceed the maximum permissible torque of actuator.

With appropriate running time for 90° / 130°:

—— Torque in continuous operation

----- Release or starting torque = short-time torque

MaxN Max. permissible torque in continuous operation for all running times

MaxB Max. permissible release or starting torque for all running times

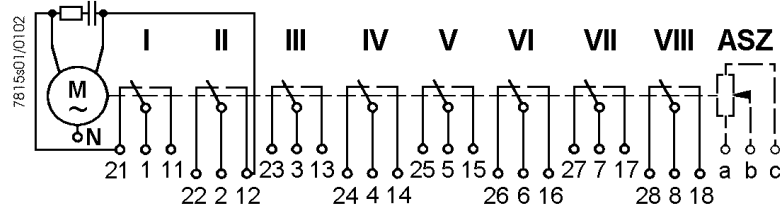
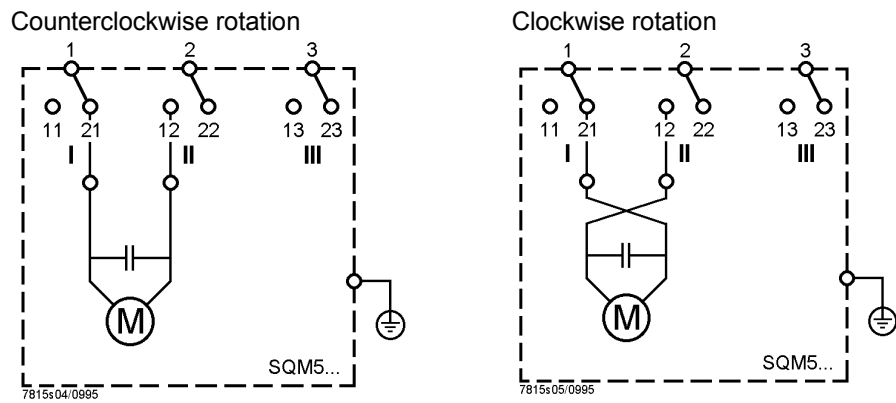

Diagram shows the maximum number of switches (2 end and 6 auxiliary switches). On versions with fewer than 6 auxiliary switches, the higher numbers are not used. For example, the actuator version with 2 end and 2 auxiliary switches does not use switches V, VI, VII and VIII.

Direction of rotation

By exchanging the 2 motor connecting cables, the actuator's direction of rotation can be changed from counterclockwise to clockwise.



Note!
When changing the direction of rotation from counterclockwise to clockwise, the cams must be readjusted.



Clockwise rotation:
Red scales on the cam shaft, double arrow on the cams.

Counterclockwise rotation:
Black scales on the cam shaft, single arrow on the cams.



Note!
Ensure correct direction of rotation!
Delivery state: Counterclockwise

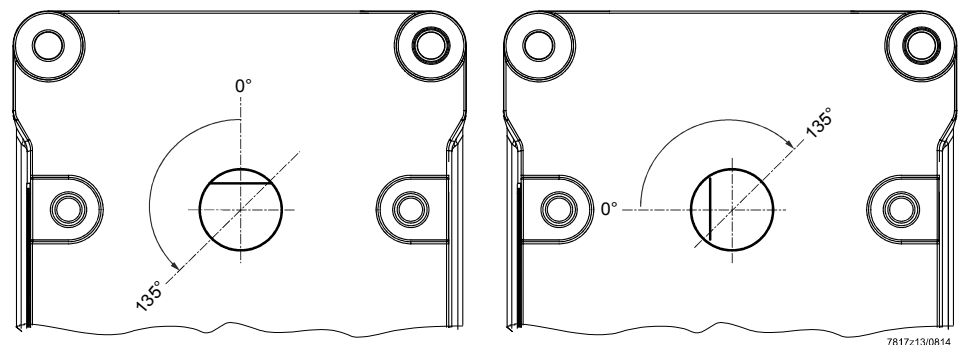

Dimensions

Dimensions in mm

SQM5...

- 1) Identical with fixing points SQM1... / SQM2...

Example: **AGA58.4**

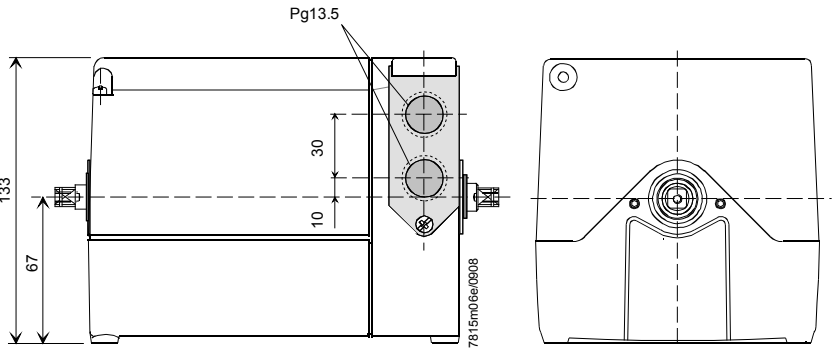
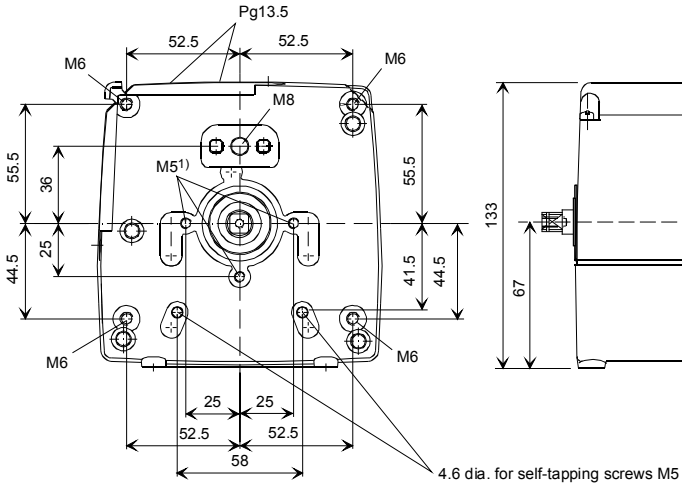
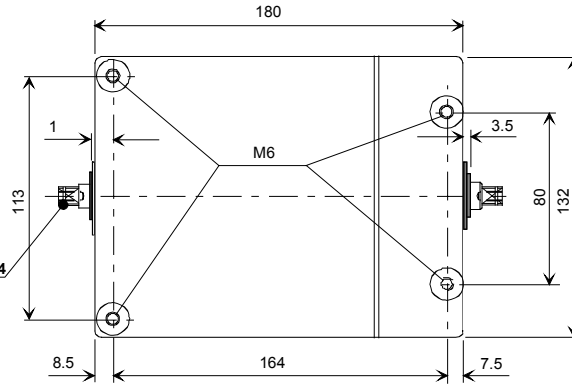

Dimensions in mm

AGA58

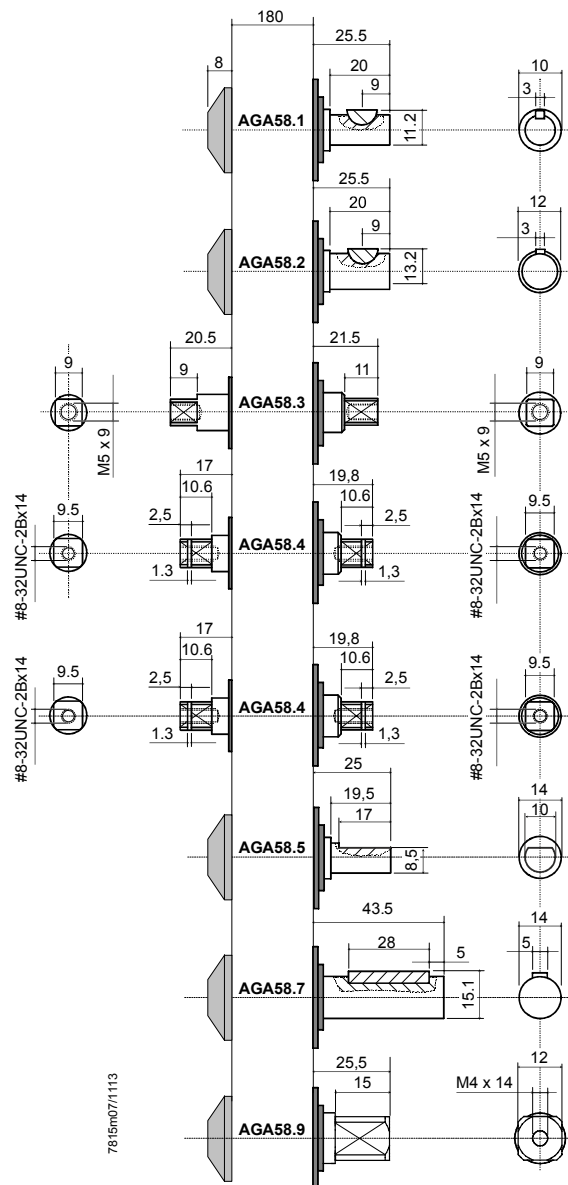

Dimensions (cont'd)

Dimensions in mm

AGA57.1

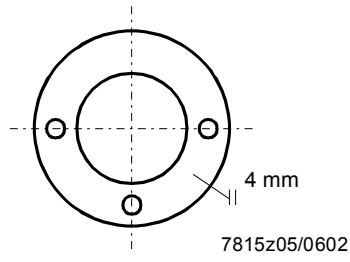

AGA57.2

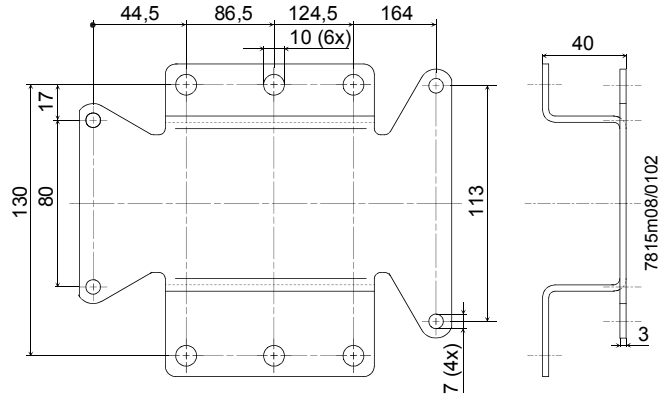

AGA57.3

